

IN-SIGHT 9912 VISION SYSTEM

The In-Sight® 9912 is Cognex's first standalone, ultra-high-resolution, area scan vision system. With its ability to acquire and process exceptionally detailed images, the 12 megapixel (MP) 9912 delivers high accuracy part location, measurement, and inspection over a large area—even when mounted at longer distances. With its all-in-one, IP67-ready form factor and easy-to-use EasyBuilder® interface, the 9912 is more cost effective and easier to integrate than most controller- or PC-based vision systems. The In-Sight 9000 series offers both area scan and line scan image capture options.

Large field of view without sacrificing resolution

The In-Sight 9912 is a 12MP smart camera vision system which allows users to see larger inspection areas while maintaining exceptional image clarity. Available in monochrome and color, the In-Sight 9912 captures detailed images to achieve higher accuracy measurements without sacrificing field of view. This also allows customers to mount the vision system away from conveyors and maintain a safe distance from hazardous equipment.

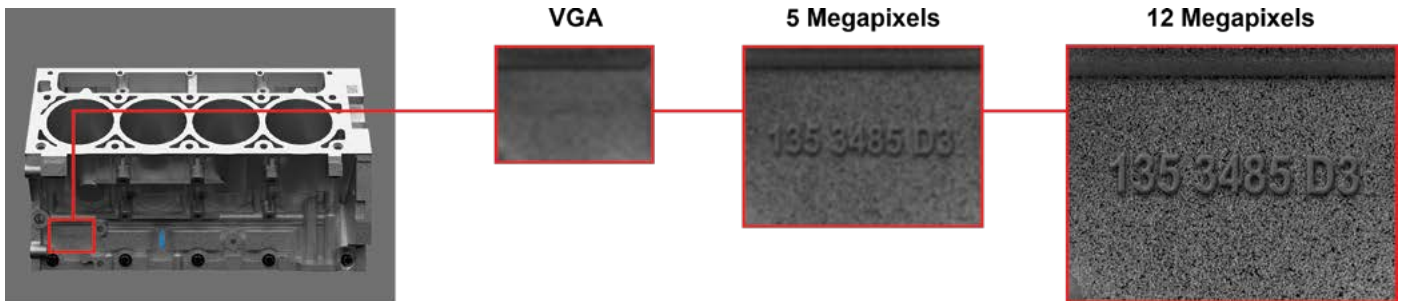

Ultra-high-resolution captures highly detailed images of part features in wide field of view—something impossible to achieve with a single lower resolution camera.

A single camera solution to multi-camera applications

The In-Sight 9912 eliminates the need for multiple cameras in applications where the objects or parts are very large. As a single camera alternative, the In-Sight 9912 reduces complexity, calibration requirements, and cost compared to multi-camera systems. The self-contained unit reduces the amount of equipment to be installed on space-restricted production lines. Plus, the IP67-rated housing protects the system from liquids and dust without the need for an external enclosure.

The In-Sight 9912 captures images of large parts, such as a metal appliance door, and still has the resolution to accurately measure the size, shape, and placement of the small stamped features on the part using a single IP67-rated smart camera.

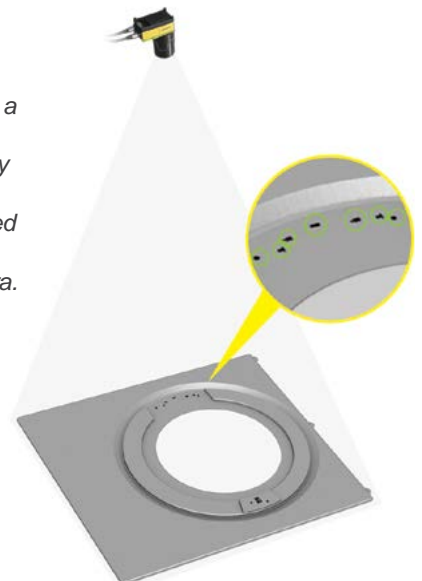

Fully configurable—no programming required

As a fully configurable 12MP vision system with an easy-to-use setup environment, the In-Sight 9912 solves applications that previously required programming on PC- or controller-based systems. The In-Sight EasyBuilder interface guides operators through a step-by-step setup process, while an advanced spreadsheet alternative offers direct access to vision tools. A single application setup environment for VGA-to-12MP vision systems allows customers to work within the same user interface, regardless of image resolution requirements or application complexity.

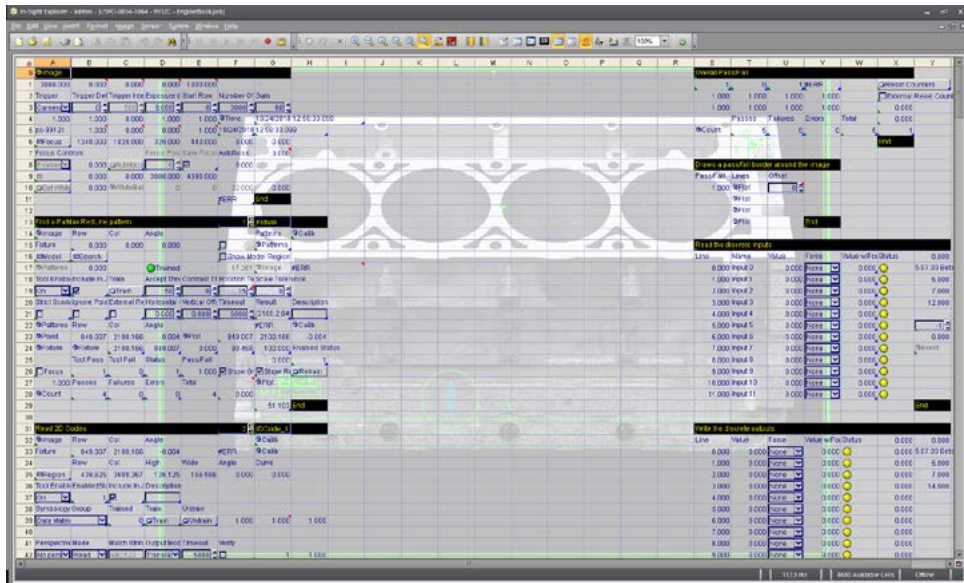

Four simple steps guide you through the setup process.

- 1
- 2
- 3
- 4

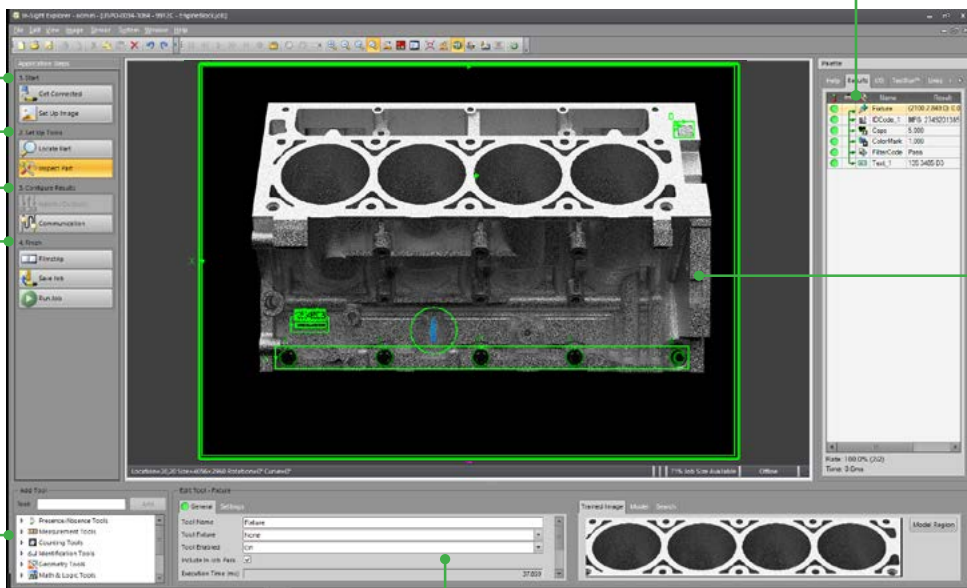

Results table— Consolidates tool results for easy viewing and helps users understand tool dependencies and performance timing.

Image-centric— Point-and-click approach lets users drop in tools quickly by simply clicking on the features of interest.

Tools palette—Comprehensive set of vision tools for locating, measuring, counting and identifying features, plus math, logic, geometry and graphic display tools.

Settings pane—Configures all vision tool parameters and settings.

Industry-leading vision tools and image processing technology

The In-Sight 9912 is equipped with Cognex's industry-leading vision tools and image processing technology, led by PatMax RedLine™—the gold standard for fast, robust, and high accuracy 2D pattern matching. The 9912 also features HDR+, which stretches the boundaries of high-dynamic-range (HDR) technology to enhance image contrast across the entire image with no reduction in acquisition speed.

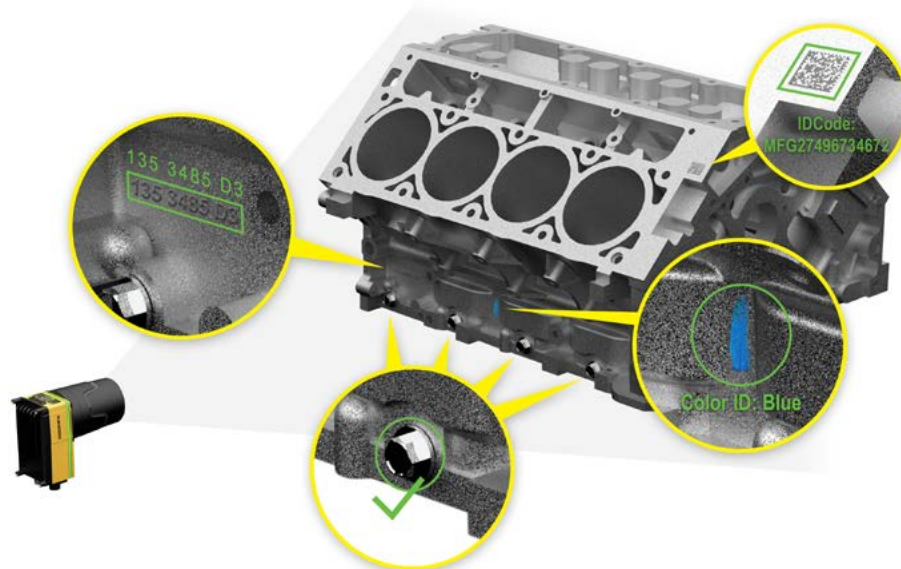

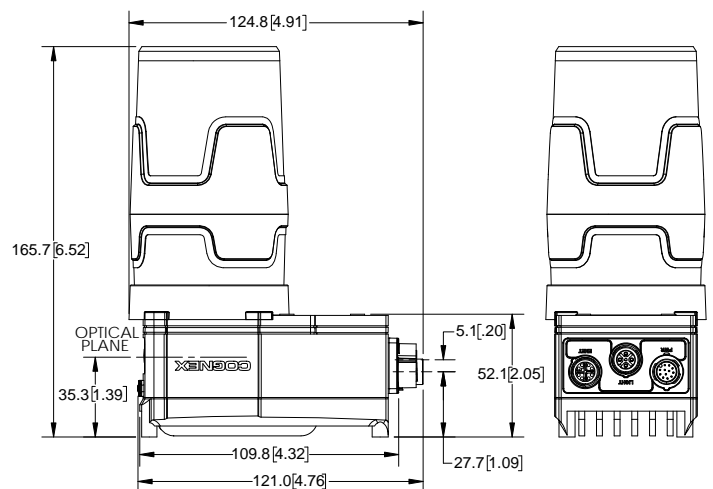
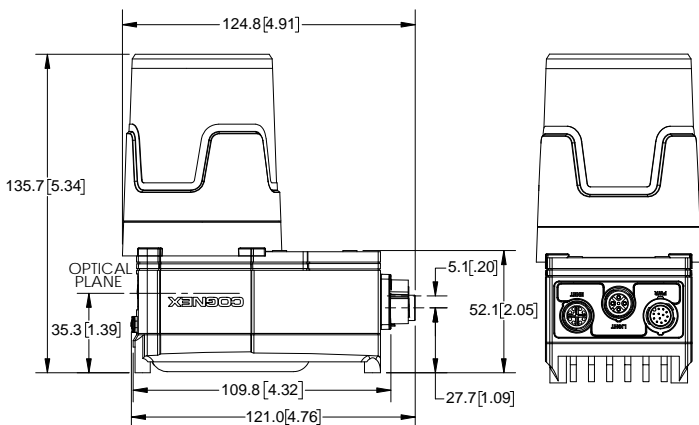
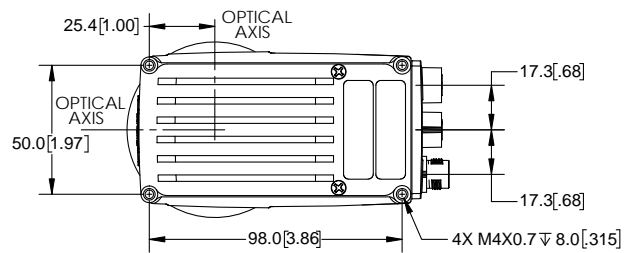
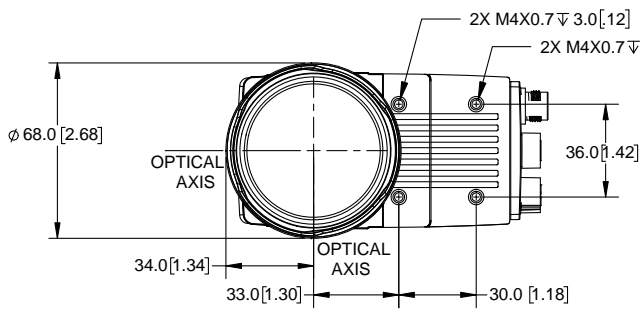
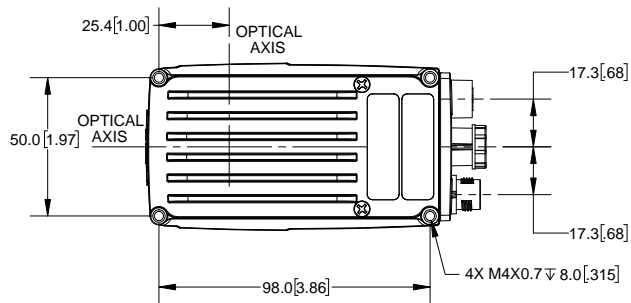
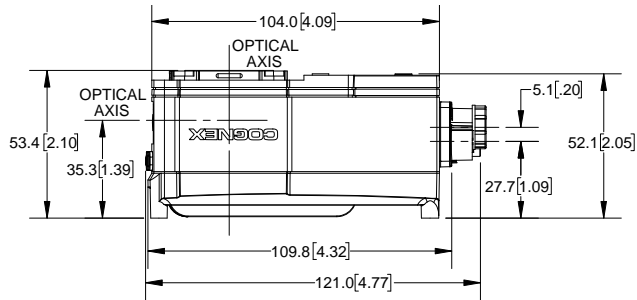
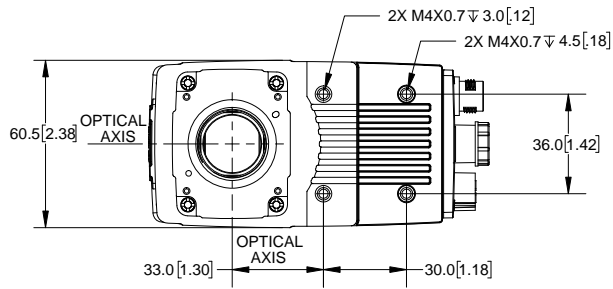

IN-SIGHT 9000 SERIES SPECIFICATIONS

		9912	9912C 	9902L
Min. Firmware		5.7		5.6.1 PR1
Image Type		Monochrome	Color	Monochrome
Imager Type		1.1-inch CMOS (3.45 μm^2 pixels)		1-inch CMOS (7 μm^2 pixels)
Image Resolution		12MP (4096 x 3000)		32MP (2048 x 16384 software configurable) or 16MP (1024 x 16384 software configurable)
Acquisition Speed (Max)		14 fps	8 fps	66 K lines per second (15us per line)
Memory	File Storage	7.2 GB non-volatile flash (jobs), 8 GB Micro SD card (jobs, images, data)		
	Processing	832 MB SDRAM		
Options	Lenses	C-mount		
	Lighting	External lights via light control connector		N/A
	Vision Tools	PatMax [®] , PatMax RedLine [™]		
I/O	Network	(1) Gigabit Ethernet (10/100/1000 Mbps)		
	Built-in	(1) Trigger, (1) General Purpose IN, (2) General Purpose OUT, (2) Bi-directional IN/OUT	(1) Trigger, (1) General Purpose IN, (2) General Purpose OUT, (2) encoder line inputs for quadrature support	
	Expansion	CIO-MICRO, CIO-1400		
Protocols	General	TCP/IP, UDP, FTP, SFTP, Telnet, SMTP, RS-232		
	Industrial	EtherNet/IP with Rockwell Add-On Profile, PROFINET, Modbus TCP, SLMP/SLMP Scanner, IEEE 1588 (CIP Sync)		
Mechanical	Dimensions	53.4 mm (2.10 in) x 60.5 mm (2.38 in) x 121.0 mm (4.77 in)		
	Weight	400 g		
	Protection	IP67 with C-mount lens cover		
Power		24 VDC		



Αθανασιάδης Χ. Καλπακίδου Κ. Ο.Ε.

Athnasiadis Ch. - Kalpakidou K. C.O.

Κεντρικό: Υποκατάστημα:
 Α. Κοραή 13 Μερόπης 11
 57010 Φίλυρο 10441 Κολωνός
 Θεσ/νίκη - Ελλάδα Αθήνα - Ελλάδα
 Τ: +30 2310 672 436 Τ / Φ: +30 210 515 7861
 Φ: +30 2310 672 437

Main: Branch:
 13th Ad. Korai str. 11th Meropis str.
 57010 Filyro 10441 Kolonos
 Thessaloniki GR Athens GR
 Τ: +30 2310 672 436 Τ / F: +30 210 515 7861
 F: +30 2310 672 437

email: contact@robovision.gr, url: www.robovision.gr